

THE CRAFT FREEMASONRY NEWSLETTER No.23 MAY 2008

TO THE GLORY OF THE GRAND ARCHITECT OF HEAVEN AND EARTH



THE MASONIC HIGH COUNCIL *The Mother High Council of the World*

COMMUNICATIONS

From the Craft Where Reigneth Peace and Silence

“The Light Shined in Darkness and the Darkness Comprehend It Not”

*"The man, whose mind on virtue bent,
Pursues some greatly good intent
With undiverted aim;
Serene, beholds the angry crowd,
Nor can their clamours, fierce and loud
His stubborn honour tame".*

BLACKLOCK

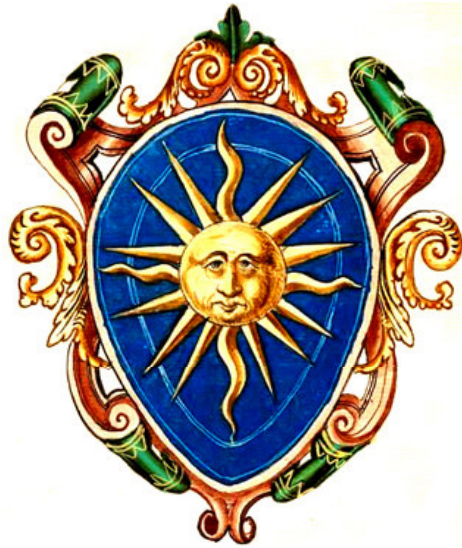

Address of the President of the Masonic High Council Mother High Council of the World

My Dear Brethren All,

I am exceptionally pleased with the work that continuously is being done by our brethren internationally. And I hope to be with you all in the Grand Assembly of the MHC the Mother High Council in Slovenia on the 26th to the 28th of September 2008.

I wish to thank our MW Brother M D for his valuable contribution in Presiding the Masonic works of Installing the Regular Grand Lodge of the Middle East on the 26th of March in Lebanon.

I would like to propose to the Grand Assembly of the MHC that the MW Brother Dorian Orz, MW Brother Juan Vicente Nunez and MW Brother Uatau Brasil de Azevedo be made Senior Grand Officers of the MHC the Mother High Council of the World.

I also would like to propose that the RW Brother Adrian Mihai Ionescu-Miu for the office of Deputy Secretary General of the MHC the Mother High Council.

I would very much like to state that the ceremony of Royal Ark Mariner in the Grand Royal Arch Chapters are of the essence and are a very much needed complement to the Degree of Master Mason. In this aspect I would like to draw your attention to the fact that this ceremony of a Royal Ark Mariner is in line with the Legend of Craft Freemasonry. In this sense I have asked to be included in this edition of our international newsletter a copy of the Cooke manuscript of 1450, which contains an account of the Legend of the Craft.

Has per this and many other reasons that it is of the essence, and fundamental that each Regular Grand Lodge prepares and duly constitutes its own Grand Chapter of the Royal Arch, Supreme Order of the Holy Royal Arch.

I wish to remind you all that the Masonic High Council the Mother High Council of the World, the Secretary General RW Brother Dimitrij Klinar and I, expect to receive communication from all Grand Inspectors Generals of the MHC the Mother High Council in regards to their findings.

I also expect to read the yearly Grand Lodge Report to the Masonic High Council the Mother High Council by the 24th of June 2008 nativity feast of Saint John the Baptist, Patron of the Craft Freemasonry.

Both written Reports must include:

1 - Name of the Grand Lodge and or Masonic Body along with the name, location and number of Lodges and Masonic Triangles.

2 - It must also include if the correct type of Regular Craft Freemasonry Ritual Workings are being used.

3 - And it must confirm that every Lodge has a Warrant or Dispensation.

4 - That all Master Masons have a Grand Lodge Certificate issued.

5 - That each Grand Lodge has organized an appending Grand Royal Arch Chapter.

6 - That each Worshipful Master and Senior and Junior Wardens have duly and regularly taken the ceremony of an Installed Master.

7 - That the Grand Lodges are performing the time immemorial ceremony of Mark Mason or Mark Man has a complement to the degree of a Fellow Craft.

Sincerely and Fraternaly,

Nikolaus Ehrenfried, MHC
President





**The Masonic High Council the Mother High Council
Grand Assembly**

Dear Brethren,

It is with great pleasure that I am writing this letter to you all.

As you probably know the Regular Grand Lodge of Slovenia is preparing the next International Grand Assembly of the Masonic High Council the Mother High Council of the World to take place in the Renaissance Castle of Dobrovo in Slovenia.

Regarding last information that we're bringing the Light to a new Regular Grand Lodge in Serbia and in this way extending to the Balkans. It is clear that it is necessary to arrange an International meeting of the Masonic High Council and study our work.

We can all recognise that the great work of our endeavours has borne fruits, namely we're daily receiving information's about lodges, which want to join our new International Federation of Regular Grand Lodges.

How beautiful it is to see the growth of our Institution The Masonic High Council the Mother High Council of the World and the delight of those our news Brethren that have joined us.

It is my privilege to be able to invite all Brethren from the United States of America, Mexico, Venezuela, Peru, Brazil, Chile, Paraguay, Argentina, Bolivia, France, Great Britain, Italy, Lebanon, Syria, UAE, Slovenia, Germany, Portugal, Serbia, Romania and Bulgaria to join us on this International Grand Assembly of the Craft September 2008 in Slovenia.

**Jan ASCHE, MHC
Chancellor**



Masonic High Council of Mexico

MAGNO EVENTO MASÓNICO

Alto Consejo Masónico Regular de México

El próximo viernes 20 de Junio del 2008 e.v., nuestro Alto Consejo Masónico de México, se verá en galardonado con la visita y representación del Alto Consejo Masónico el Alto Consejo Madre del Mundo, el cual entregará de manera Oficial la representación de Inglaterra para México, dando con esto el inicio de una masonería representativa, antigua, pero sobre todo buscando la unificación, crecimiento y superación bajo los principios mas sublimes de nuestra Orden en México. En esa misma ceremonia, el Alto Consejo Masónico de México otorgará la Carta Patente que legaliza la constitución de la Gran Logia Regular York de México.

La Muy Respetable Gran Logia Regular York de México, Antigua y Honorable Fraternidad de Libres y Aceptados Masones, es la primer Gran Logia confederada al Alto Consejo Masónico Regular de México, bajo los auspicios del Alto Consejo Masónico el Alto Consejo Madre del Mundo. Esta Gran Logia con jurisdicción en toda el territorio de los Estados Unidos Mexicanos, es la primer Gran Logia Multiritualista en México, esto es, con la facultad y autoridad para otorgar Cartas Patentes a cualquier Logia para que enfoquen su trabajo masónico de acuerdo al Rito Regular que así lo deseen, por ejemplo: el Rito Ingles Antiguo, Rito de Claremont, Rito Escocés Rectificado, Rito Antiguo y Primitivo, entre otros. El día 21 de Junio del 2008 e.v. la Gran Logia Regular York de México llevará a cabo su 2a Gran Comunicación Anual en la ciudad de Cuernavaca, Morelos, México.

Próximamente aparecerá publicado en este blog el programa Oficial tanto del evento del Alto Consejo Masónico de México, como el programa oficial de la 2a Gran Comunicación Anual de la Gran Logia Regular York de México.

T.:T.:G.:O.:T.:S.:A.:O.:T.:U.:

Regular Grand Lodge of the Middle East

In the very early light of dawn, and after much hard work and a long wait, we finally started to receive our dear and valuable Brethren from the four points of the globe. We were honoured by the visit of the Vice President of the Masonic High Council the Mother of the World and the Secretary General of the MHC our RW Brother Dimitrij Klinar.

The final and precious gift was the arrival of our MW Brother H.E. Rui Alexander Gabirro. The picture was more than perfect, and better than expected. Our joy was with all the Brothers and it was truly appreciated. It was the result of all the brave efforts, especially by the giant efforts done by our MW Brother Khaled, whose health situation is still our great concern till this hour.

The schedule was completed as planned, and Lebanon the Land of the Tall Cedars received the sons of Hiram, our Master and Teacher, may this visit be blessed to all our Brethren through out the world. So, it was a must to pay back the gratitude for the Great country and its Great men.

The trip to Byblos City of Gods and Craftsmen was the beginning of fascination, followed by the also ancient state city of Tyre, house and City of Master Hiram Abiff, who was among the earliest Architects.

The Masonic trip to Lebanon was a success. The great Tall Cedars ought to be visited as well. Those Majestic trees, immortals that stood up to all the harshness of History and Time.

And as it has always been, The Regular Grand Lodge of The Middle East was born, and from Lebanon itself; the country that was all through History the Womb for all Major Great events.

Lebanon has always been the Gate to all Grand events and all Great deeds. We shall always be the craftsmen who will protect and defend the Craft, which started and flourished in Lebanon, and will always be.

We pray for our G.:A.:O.:T.:U.: to protect our dearest Brethren and us.

And we join in Unity and Fraternity in prayers for all of the Brothers, and especially our MW Brother Khaled. May all our works be blessed,

MHC of the Middle East



Now in the National Museum of Lebanon this pectoral set was buried in King Ibshemuabi's tomb in Byblos more than 3800 year ago.



Masonic High Council of the United States of America



Regular Grand Lodge of Texas

List of affiliated Regular Craft Lodges

Laredo Lodge No.1

Network Lodge No.2

Caleb Lodge No.3

Conroe Lodge No.4

Elijah Lodge No.6

Abel Lodge No.8

Damascus Lodge No.9

Melchidek Lodge No.11

H. B. Turner Lodge No.12

Obed Eden Lodge No.13

Corpust Christi Lodge No.14

Galveston Lodge No.15

New elected and appointed Grand Officers

RW Darryl Jenkins, Junior Chancellor

RW Pierre Guffie, Grand Charity

RW Tommy Jones, Grand Master of ceremony

RW Greg Allen, Assistant Grand Treasurer

RW Tony Lett, District Deputy Grand Master



Grand Lodge of the Masonic High Council of Serbia

MW & RW Senior Grand Officers and Brethren: I have the honour to give notice that the Masonic High Council, the Mother Masonic High Council of the World, will install in a Regular Masonic Ceremony of Consecration the newly formed Grand Lodge of Serbia will be on 24th of July 2008 in the city Sremska Mitrovica at 15:00pm.

Velika Loža Visokog MASONSKOG Saveta Srbije

List of affiliated Regular Craft Lodges

Pobratim Or Beograd Lodge No.1
Sveti Jovan Or Sremska Mitrovica Lodge No.2
Dositej Obradovic Or Kragujevac Lodge No.3

Masonic High Council of Brazil

MW & RW Senior Grand Officers and Brethren: I have the honour to give notice that the Masonic High Council of Brazil, has establishment in due form a new Grand Lodge in the State of Parana, Brazil.



Grande Loja Regular de São Paulo

Antiga e Honorável Fraternidade de Maçons Livres e Aceitos

Relação de Lojas Simbólicas Regulares & Triângulos Maçônicos Afiliados

São Paulo

ARLS Perfeita União No.1

Rito Antigo e Aceito, Or.: de Itatiba, São Paulo

ARLS Luz de Hórus No.2

Rito Antigo e Aceito, Or.: de Itatiba

ARLS Cruzeiro do Sul No.3

Rito Antigo e Primitivo de Mênphis, Or.: de Jundiaí, São Paulo

ARLS Cavaleiros da Luz No.4

Rito Antigo e Primitivo de Mênphis, Or.: de Taubaté, São Paulo

Rio de Janeiro

Triângulo Maçônico Orvalho de Hermon No.1

Rito Regular do Ofício, Or.: de São João do Meriti – Rio de Janeiro

Rio Grande do Sul

Triângulo Maçônico Virtude e Silêncio No.17

Antigo Rito Inglês – 1730, Or.: de Cachoeira do Sul – Rio Grande do Sul



Grande Loja Regular do Paraná

Antiga e Honorável Fraternidade de Maçons Livres e Aceitos

Relação de Lojas Simbólicas Regulares & Triângulos Maçônicos Afiliados

ARLS União Fraternal No.1

Rito Antigo e Aceito, Or.: de Campo Largo

ARLS Cavaleiros do Oriente No.2

Rito de York, Or.: de Campo Largo

ARLS Rei Salomão No.3

Rito Antigo e Primitivo de Mêmphis, Or.: de Campo Largo

Syria

MW & RW Senior Grand Officers and Brethren: I have the honour to give notice that the Masonic High Council of the Middle East, the Regular Grand Lodge of Middle East, has establishment in due form of a new Syrian Masonic Lodge.

Ebla Lodge No.1

The Secret of our Stretch

A speech by our

RW Bro. Robert Kale, Assistant Grand Secretary of the
Regular Grand Lodge of Middle East

“One Body One Family”

When I was young, my father once called me and asked me the following question:

My Father: What does a man need to walk?

I: For a man to walk he needs legs!

My Father: You're certainly right my son. However, your answer is only partially true. Have you tried to walk with your eyes closed.

So, I closed my eyes, and suddenly I realized I was unable to walk. I apologized, and rectified:

I: For one to walk one needs both legs and eyes.

My Father: You're correct, my son but your answer is still only partial true! Your eyes are like a camera; they catch an image and send it to your brain. Your brain will give order to your legs to move right, left or forward. If your brain is sick, even if you see, you can't correctly move.

I: Why, is my body so complicated?

My Father: The body is simple but you must be aware that any part of your body is directly linked to all the other parts. If you have pain in one of your nails, all your body may suffer. So, my dear son, protect all parts of your body.

I was, really, amazed with that discussion but I didn't get the purpose of it. To which my father added:

My Father: What if instead of one brain, you have ten? What about having twenty legs and hands?

I: I would be the most powerful man on earth, dad! I could be an Olympic champion!

My Father: You may have all that. But don't think about power. Go, find the solution to have fifty brains, then come back to me: I would love to see you so happy! And never forget: in darkness you can't move ahead...

I, never, came back to my father for that purpose as he died too early.

Many years have passed since, and, one day, I decided to join the Masonic Federation. I will never forget the first meeting. When I opened my eyes and went out from the darkness, I saw around me forty-nine people. All came to congratulate me, calling me: brother!

I, suddenly, realized, what my father, long years ago, told me: I felt I have, now, fifty brains, one hundred legs, one hundred hands and so...

The Masonic spirit is like a human body. We, all, are linked together and have one brain, one heart. I feel, now, it is my responsibility to protect all my brothers and I'm quite sure they do the same to me wherever they are.

That is the secret of our stretch.

What about the concept of "Brother"? Till that day, I knew that I have two brothers. Of course, I love them as members of my family. But, I never decided to have them. My parents, even, didn't choose them. We, all, came by procreation and we feel lucky to be together.

However, the concept of "Brother" in the Masonic spirit is quite different. Nobody enters, there, by accident or by procreation. We are all co-opted. In other words, I can choose my brothers, now. Isn't, here, the ultimate sign of our power? By correlation, I could, also, say: I choose all the members of my body...

Come join me, and be my Brother!



The Church of St. Michael's

On Barje was built by Slovenian architect Josef Plecnik (1872-1957) in periods during 1920-28 and 1937-40 in a small village near the capitol of the present state of Slovenia. This church is one of the most peculiar compositions in his vast opus of architectural 'perversions'. The following analysis will try to dissolve the many layers of meaning that are always present in Plecnik's work, be it a single house or the royal cathedral 'Srdca Jezusovega' in Prague. But this church is something special in terms of symbolism, for never was Plecnik so explicit as here. But to be sure, there is no proof existing that he knew anything at all about the ideas revealed in this analysis. Even though he was a teacher he passed on no direct knowledge of the composition, even less of the symbolism implied when dealing with measures or numbers. His austere, christian-ascetics appearance would deny any such 'accusations', even more, he would gladly donate some wood for the burning of the heretic - his words. Still, encouraged mostly by the ignorance, another portrait of an architect will be presented.

Archangel Michael was Plecnik's most favorite protector, and he placed a leaden plastic of angel on the facade of one of his first architectural achievements, the Zahrl House in Vienna. Even though Michael is the most popular christian angel and protector of Israel it is rarely mentioned in the Bible (Dan 10:13, 21, Jud 1:9, Rev 12:7). It is also believed that Michael appeared to Moses as the fire in the burning bush. Definitely it is the most highest of angels, sometimes mingled with the deity itself, being IHVH,

the ineffable name of Jews, or the Christ of Gnostics. Michael's roots are mostly in Egyptian god Toth and its Greek variant Hermes or Roman Mercury. Usually, his attributes are a sword and a pair of scales, perhaps echoing the final judgment of 'weighting of the souls' in Duat with Toth present as the scribe of the verdict. He is the Archangel of Fire and the Angel of the Sphere of Sun, equivalent with the cabalistic sephira Tiphareth.

The foundation of the ground plan consists of ten, carefully placed, pillars: four in the sanctuary and six on the circumference of the composition. Plecnik's intent was to represent the cabalistic Tree of Life with its ten spheres. Supporting this idea is the value of the total length **23.30 m** or 233 dm which is equivalent to the gematric value of Hebrew OTz HChIIM, Tree of Life:

$$\text{OTz HChIIM} = (70+90)+(5+8+10+10+40) = 233$$

The most obvious allusion to the cabalistic Tree of Life are the openings of the tower, in fact the whole tower with its climbing stairs is a symbolic Tree of Life. The 'number 10' or Malkuth - the doors of the home of the priest - is hidden beneath the stairs leading to the entrance of the church which is on position 9, equivalent to Yesod (The Foundation). Yesod is the sphere of Moon and in human anatomy it corresponds to the generative organs. The width of the tower is 5.10 m, a synonym for Michael in simple Latin gematria:

$$\text{MICHAEL} = 13+9+3+8+1+5+12 = 51$$

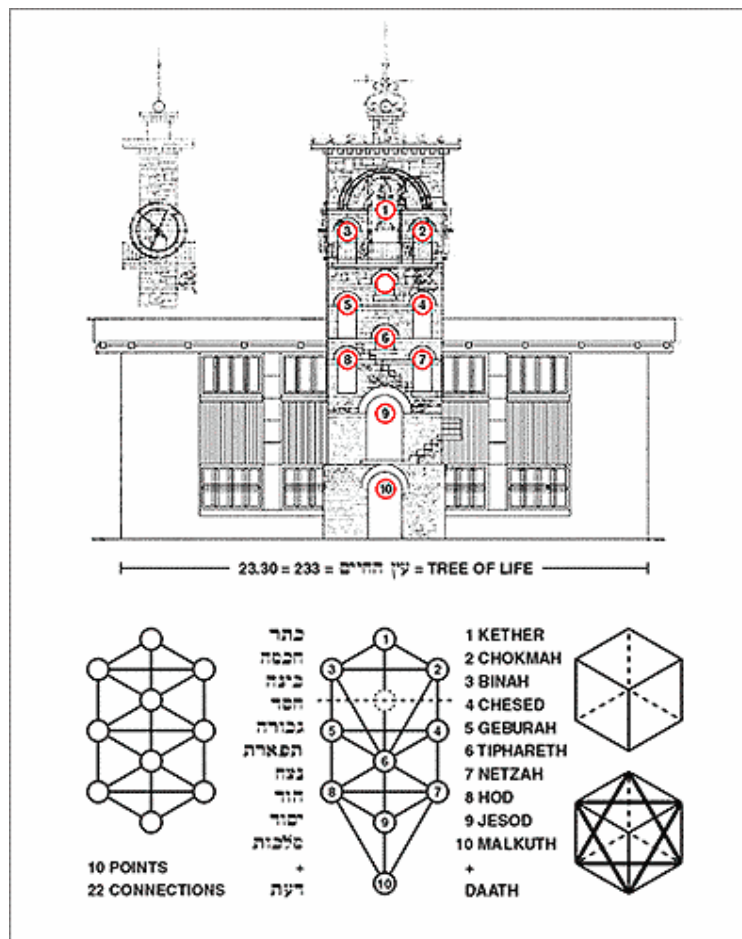

Tree of Life projected on the tower

The Latin version would be LIGNUM VITAE with the gematric value 133 according to simple Latin gematria¹, which is synonymous with the width of the church **13.30 m** (133 dm):

$$\text{LIGNUM VITAE} = (12+9+7+14+21+13)+(22+9+20+1+5) = 133$$

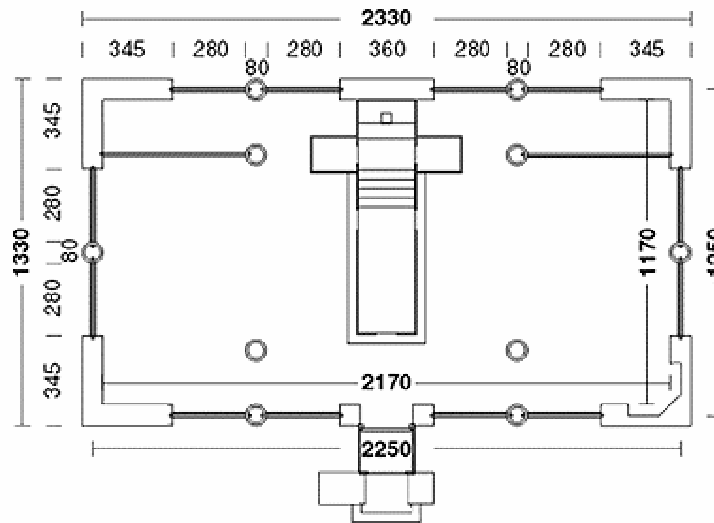

Ground plan - drawn after the original copy

The module of the composition is 125 cm, number equivalent to the gematric signature of the architect:

$$\mathbf{JOSEF\ PLECNIK} = (10+15+19+5+6)+(16+12+5+3+14+9+11) = \mathbf{125}$$

The general dimensions are proportioned according to the 'rule of small numbers' (cf. Vitruvius). The breadth between the axis of the walls is 12.50 m while the width measures 22.50 m. Both main axial measures of the floor plan have cubical nature, since $125 = 5^3$, and $225 = 1^3+2^3+3^3+4^3+5^3$. The ratio is thus 10:18 or 5:9, numbers from the fourth Fibonacci series: 1-4-**5**-9-14... The pillars are positioned to fit a special Pythagorean diagram consisting a rectangle 8:6 (also 4:3, Pythagorean triangle) with circumscribed circle of radius 5. All numbers from 1-10 are generated from this diagram, with exception of number 7 approximated as $5 \times \sqrt{2}$ which is close to 7.2.

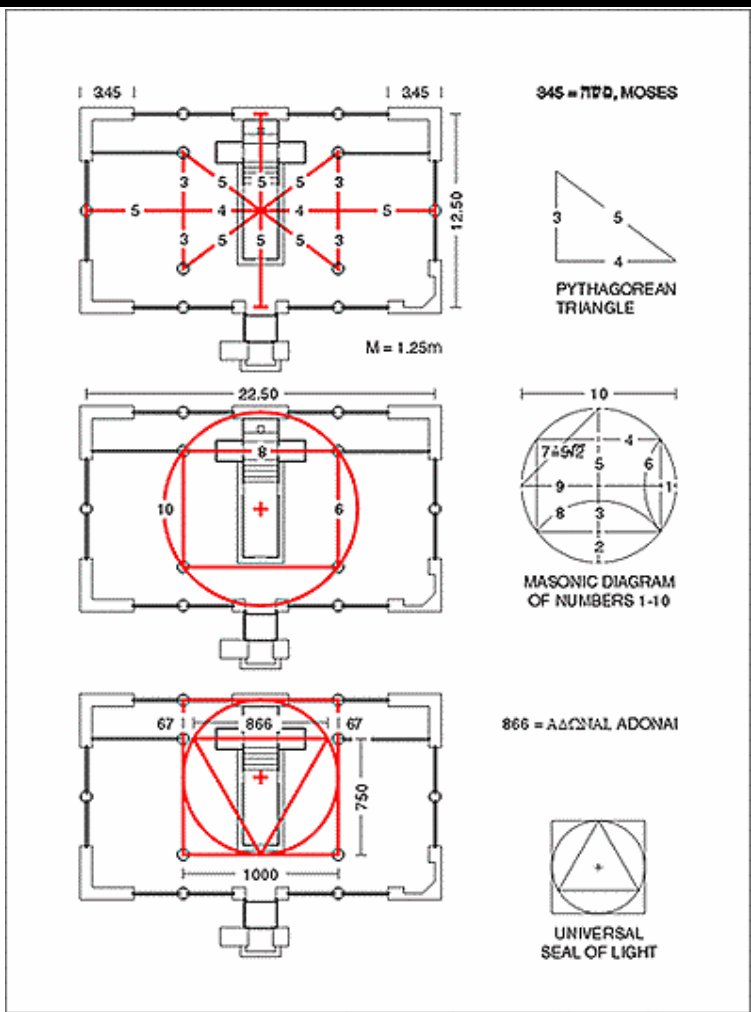

St. Michael - composition of the floor plan

One of the methods of divination is called geomancy, described in every serious book of western occultism, mentioned also by classics like Agrippa in De Occulta Philosophia. Sixteen lines of holes are drawn with a stick into the desert sand without counting. The holes in every line give one dot or two, depending if the number of holes is odd or even. Every four lines form a figure that divinator interprets.

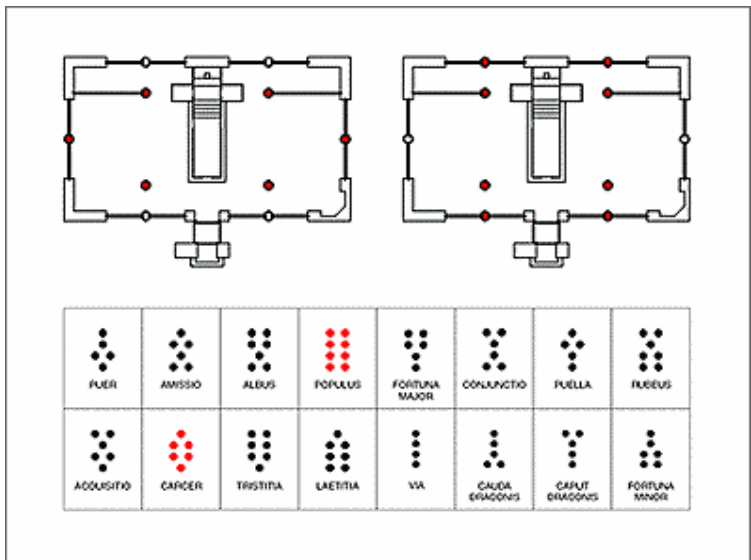

Pillars forming geomantic figures

The middle six pillars along the breadth of the floor plan represent geomantic figure CARCER, prison, a symbolic representation of the abyss into which Michael threw that old serpent, which is Devil, and Satan for thousand years3:

Rev 20:1 And I saw an angel come down from heaven, having the key of the bottomless pit and a great chain in his hand.

20:2 And he laid hold on the dragon, that old serpent, which is the Devil, and Satan, and bound him a thousand years,

20:3 And cast him into the bottomless pit, and shut him up, and set a seal upon him, that he should deceive the nations no more, till the thousand years should be fulfilled: and after that he must be loosed a little season.

Six pillars across the length of the plan represent geomantic figure POPULUS, Congregation. The dimensions of the cubus of the main building are 7.50 m height, 12.50 m width, and 22.50 m length. This numbers are in the ratio of 3:5:9, resembling the gematric value of Hebrew name for the Adversary:

$$\text{ShTN} = 300 + 50 + 9 = 359$$

The overall story is therefore very simple: the upright triumphant Michael with the fallen Adversary beneath.

The composition of the central part of the sanctuary is made of three cubes with sides 7.50 meters or 6 times the module 125 cm. This spatial proportioning resembles the composition of the Tabernacle as described in Exodus, and the composition of Solomon's temple which is the later elaboration of the Tabernacle in the Wilderness. Again, the three cubes are a metaphor of the Tree of Life since this diagram can be projected on three cubes.

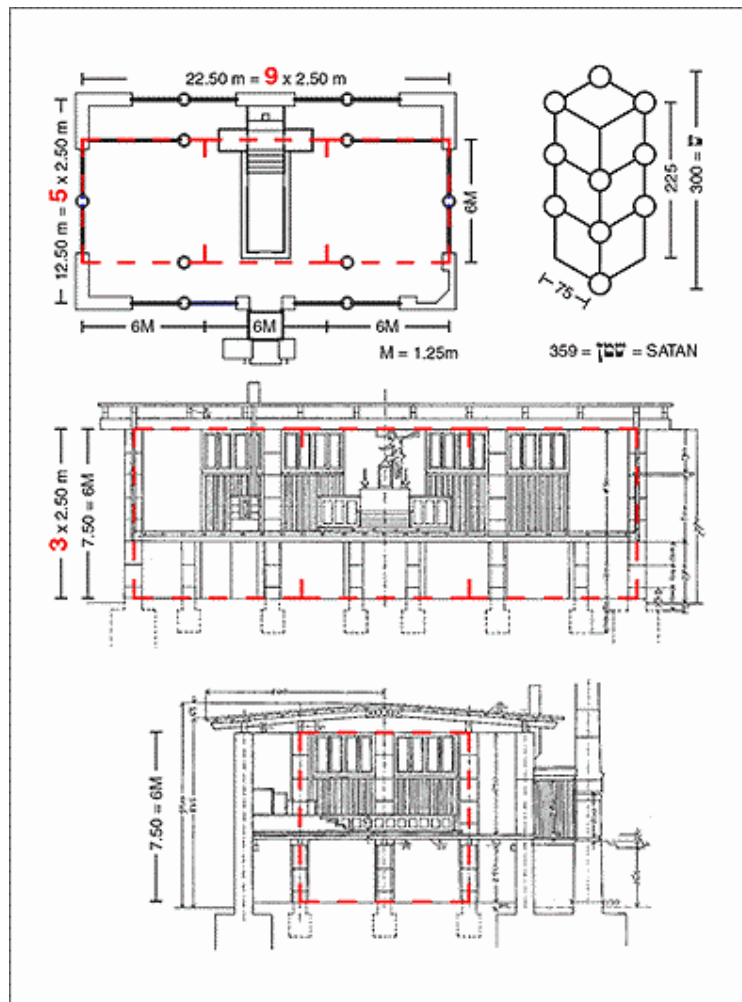

Cube as compositional principle

A cube of 6 modules has some specific characteristics that contribute to the general idea written in architecture. Pythagorean much venerated the figural numbers and especially the cube built of calculii, which they called 'metacube'. Even the original word in Greek, Gk. METAKYBOS = 888 emphasizes the symbolic importance. The metacube of 6 (6 modules of the composition) has 91 visible calculii, whereas 125 (a cube of 5) are hidden to the eye. All numbers of the metacube are important: 216, 125, and 91:

216 = DBIR, The Holy of Holies in the Temple of Solomon

125 = JOSEF PLECNIK

91 = MLAK, Angel

DBIR, Devir was the most sacred part of the Temple of Solomon, a cubical oracle entered only once a year by the High Priest to receive the prophecy. It was also called Holy of the Holies and contained the Ark of Covenant guarded by the two Cherubim, and it was said that between the Cherubim the Holy Presence dwelt, the Shekinah. The hidden part of metacube 6 is the cube of 5 and Plecnik demonstrated the use of these two cubes, 5 and 6, at the entrance of the church, which is composed entirely with these numbers. The visible part of calculii, 91, is the number of Angel in Hebrew gematria, the Messenger. The metacube 6 contains the key to the ideas embedded in the church of St. Michael's: the Seer(125) within the Sanctuary(216)4 invoking the Angel(91). The main width, 23.30 m, is also synonymous with Greek spelling for Oracle, Gk. Logion = 233. The composition as presented is based on a geometry of a circle, a triangle, and a square, interlaced in a seal called The Universal Seal of Light or sometimes Hermes' Seal. Corresponding numbers 3, 4, and 1, resemble Hebrew word MShA, Oracle, with gematric value 3415.

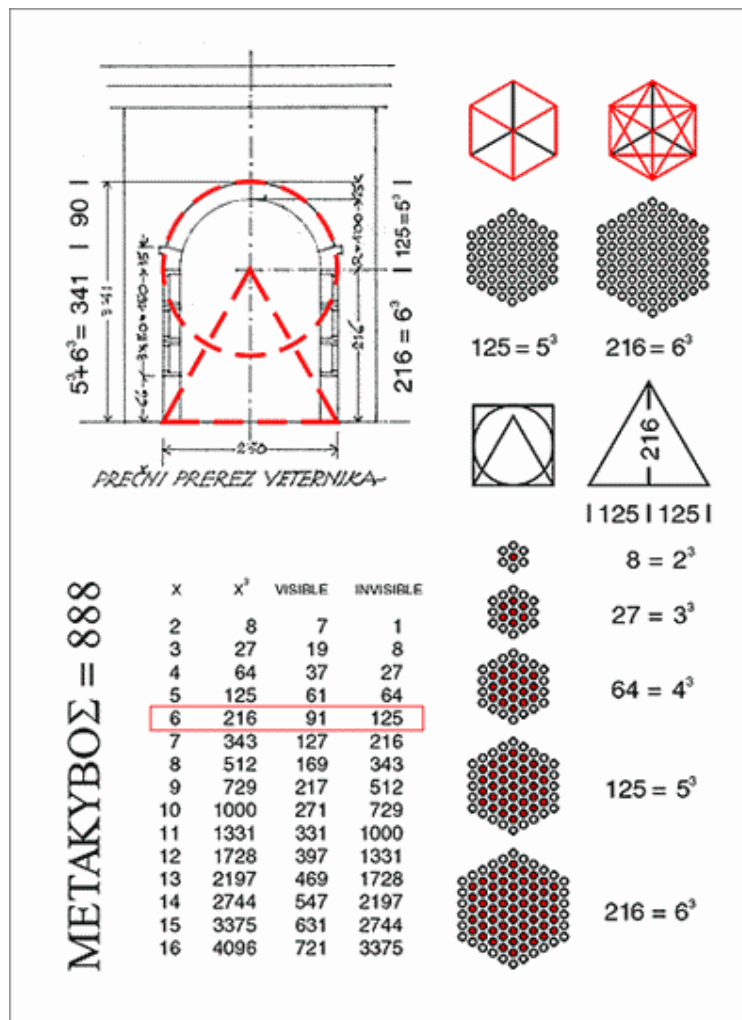

In order to communicate with angels conjurer must be familiar with the method, and one of the most famous western grimoires is Lemegeton Clavicula Salomonis or The Lesser Key of Solomon, also very popular during the Magickal Revival at the beginning of twentieth century (Mathers, Crowley, Waite et

a). The middle part of the ground plan much resembles the Hexagram of Solomon as described in the grimoire:

This is the form of the Hexagram of Solomon, the figure whereof is to be made on parchment of a calf's skin, and worn at the skirt of thy white vestment, and covered with a cloth of fine linen white and pure, the which is to be shown unto the Spirits when they do appear, so that they be compelled to take human shape upon them and be obedient.

(Colours. - Circle, Hexagram, and T cross in centre outlined in black, Maltese crosses black; the five exterior triangles of the Hexagram where Te, tra, gram, ma, ton, is written, are filled in with bright yellow; the T cross in centre is red, with the three little squares therein in black. The lower exterior triangle, where the Sigil is drawn in black, is left white. The words "Tetragrammaton" and "Tau" are in black letters; and AGLA with Alpha and Omega in red letters.)⁶

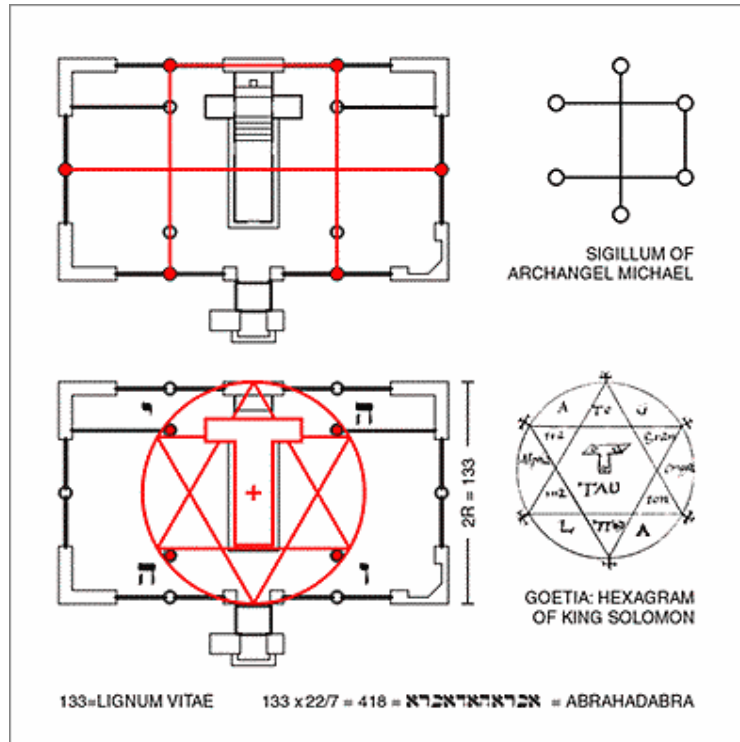

Goetic seal

Notice, that the four pillars within the circle stand for the four letters of the Ineffable name IHVH. The Sigillum of Archangel Michael drawn over the ten pillars is also obvious.

THE FINAL JUDGMENT

Rev 1:17 And when I saw him, I fell at his feet as dead. And he laid his right hand upon me, saying unto me, Fear not; I am the first and the last:

1:18 I [am] he that liveth, and was dead; and, behold, I am alive for evermore, Amen; and have the keys of hell and of death.

The whole key of the composition, together with the basic idea, is incorporated into the chandelier hanging before the altar. A peculiar circular chandelier, with a pendant cross and a pair of scales with sword hanged from it, is a sigillum of of the Final Judgment as prophesied in John's Revelation and other apocalyptic and Gnostic texts - a metaphor in which archangel Michael defeats the antichrist at the second coming of the Messiah and establishes the 'Civitas Dei'.

It is proportioned with previously mentioned 'a circle, a triangle, and a square', and a pentagram to complete the sequence 3-4-5. The idea of Judgment and resurrection is comprised on the Tarot card XX: The Judgment, an older variant is also called The Angel. The correspondences of the card are Fire and the Hebrew letter Shin, traditionally the letter of Spirit. The trump presents the Archangel of the Solar Fire Michael which blowing the trumpet heralds the descent of the Holy Spirit and the resurrection of the dead.

1Th 4:16 For the Lord himself shall descend from heaven with a shout, with the voice of the archangel, and with the trump of God: and the dead in Christ shall rise first:
 4:17 Then we which are alive [and] remain shall be caught up together with them in the clouds, to meet the Lord in the air: and so shall we ever be with the Lord.

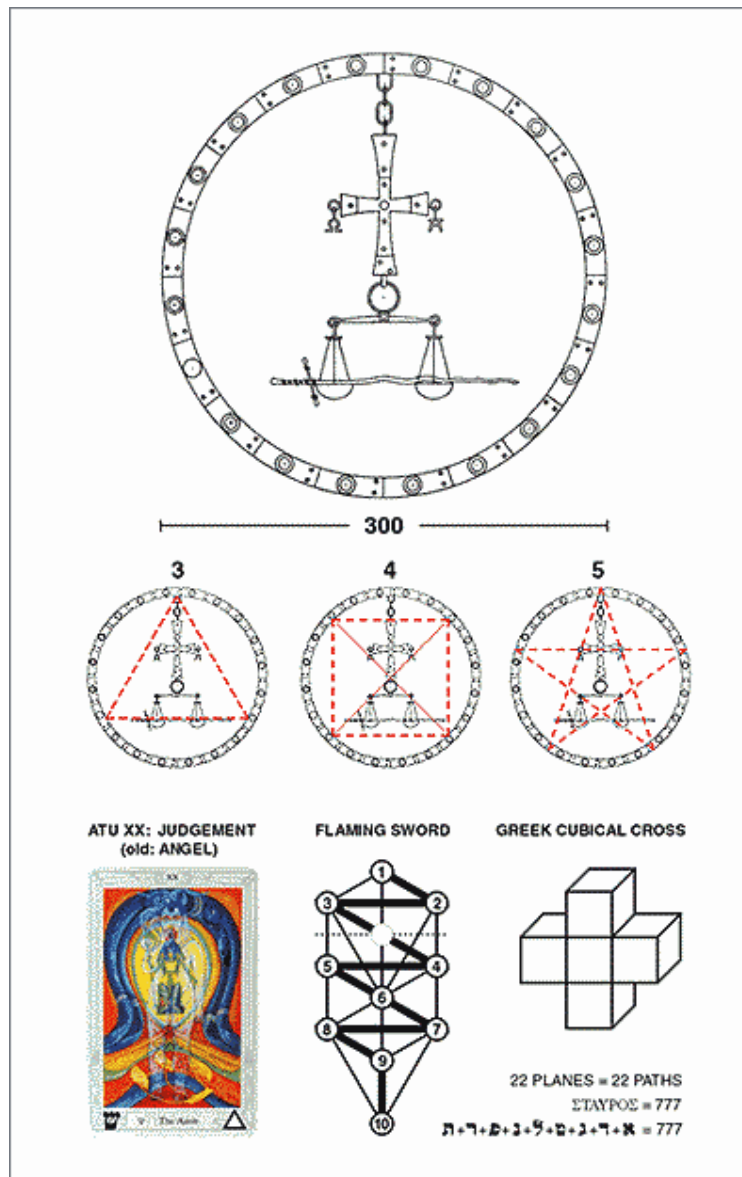

Final Judgement

Twenty lights on the circumference are direct association on trump XX. The upright, compositional, triangle is a glyph of Fire, whereas the outer dimension of the chandelier, 300 cm, is a synonym of Shin since its gematric value is 300. According to cabalistic analogy 300 is also the sum of the expression Spirit of Gods:

ShIN = 300 = RVCh ALHIM, Spirit of Gods

A cross is suspended from the circumference of the chandelier with ten decorative rivets for each sephira of the Sephiroth, and Alfa and Omega symbolizing the paths between them. Greek word for Cross is

STAUROS = 7777

with the same value as the sum of the Paths that like the lightning connects all sephiroth from Kether to Malkuth. It is also called the Flaming Sword, known to the eastern mysticism as a Kundalini. The winding of the sword's blade may represent exactly this Flaming Sword. The cross is carrying a pair of

scales balanced by the sword resting on them. The Middle Pillar of the Tree of Life represents the equilibrium of the antonyms and leads from Malkuth via Yesod, Tiphareth, and Daath to Kether. Often it is called the Path of Messiah. Plecnik scribes this idea with a pair of scales and the sword balancing them:

ChRB (Sword) + MAZNIM (a pair of scales) = 358 = MShIH, Messiah

The symbolism of a pair of scales and the tongue of decree measuring between them is known from the cabalistic text called Sepher Yetzirah when describing the Three Mother Letters Aleph, Mem, and Shin⁸, the foundation of the Tree of Life⁹:

SY 3:1 Three Mothers: Alef Mem Shin

Their foundation is

a pan of merit

a pan of liability

and the tongue of decree deciding between them.

Notes

1 - Rule of simple Latin gematria is A=1, B=2, ... , Z=26.

2 - This approximation is close: $5 \times \sqrt{2} = 7.07106$.

3 - The horizontal distance between the middle pillars is 1000 cm.

4 - Devir, Holy of Holies, the Sanctuary, etc. is always Tiphareth, the sixth sephira of Sun, the conjunction of Microprosopus and Macroprosopus. Along the path of initiation it is Knowledge and Conversation with Holy Guardian Angel that takes place in Tiphareth.

5 - 341 is the sum of Three Mother Letters - Alef, Mem, Shin - the foundation of the whole alefbeth (Sefer Yetzirah).

6 - Taken from The Book of the Goetia of Solomon the King, trans. A. Crowley, First Impressions 1993.

7 - Gk. ST is taken as digamma with value 6.

8 - Aleph, Mem, and Shin have the value 341 (a triangle, asquare, and a circle) a symbol of the proportional key used in the composition.

9 - Sefer Yetzirah - The Book of Creation, trans. A. Kaplan, Weiser 1991.

Origin of Masonry, and its general Advantages

RW Brother William Preston 1812

From the commencement of the world, we may trace the foundation of Masonry. Ever since symmetry began, and harmony displayed her charms, our Order has had a being. During many ages, and in many different countries, it has flourished. No art, no science preceded it. In the dark periods of antiquity, when literature was in a low state, and the rude manners of our forefathers withheld from them that knowledge we now so amply share, Masonry diffused its influence. This science unveiled, arts arose, civilization took place, and the progress of knowledge and philosophy gradually dispelled the gloom of ignorance and barbarism. Government being settled, authority was given to laws, and the assemblies of the Fraternity acquired the patronage of the great and the good; while the tenets of the profession diffused unbounded philanthropy.

Abstracting from the pure pleasures, which arise from friendship so wisely constituted as that which subsists among Masons, and which it is scarcely possible that any circumstance or occurrence can rase, Masonry is a science confined to no particular country, but extends over the whole terrestrial globe. Wherever arts flourish, there it flourishes too. Add to this, that by secret and inviolable signs, carefully preserved among the Fraternity, it becomes a universal language. Hence many advantages are gained: the distant Chinese, the wild Arab, and the American savage, will embrace a brother Briton, and know, that besides the common ties of humanity, there is still a stronger obligation to induce him to kind and friendly offices. The spirit of the fulminating priest will be tamed, and a moral brother, though of a different persuasion, engage his esteem: for mutual toleration in religious opinions is one of the most distinguishing and valuable characteristics of the Craft. As all religions teach morality, if a brother be found to act the part of a truly honest man, his private speculative opinions are left to God and himself. Thus, through the influence of Masonry, which is reconcilable to the best policy, all those disputes which embitter life, and sour the tempers of men, are avoided; while the common good, the general object, is zealously pursued.

From this view of our system, its utility must be sufficiently obvious. The universal principles of the art unite, in one indissoluble bond of affection, men of the most opposite tenets, of the most distant countries, and of the most contradictory opinions; so that in every nation a Mason may find a friend, and in every climate a home.

Such is the nature of our institution, that in the lodge, which is confined to no particular spot, union is cemented by sincere attachment, and pleasure reciprocally communicated in the cheerful observance of every obliging office. Virtue, the grand object in view, luminous as the meridian sun, shines resplendent on the mind, enlivens the heart, and heightens cool approbation into warm sympathy and cordial attention.

The Cedar Tree - Cedrus Libani

There are three or four species of cedar tree throughout North Africa and Asia. The most famous of these is the Cedar of Lebanon, which was mentioned in the Old Testament, although today only a few of the original groves still exist. In antiquity the cedar forests covered great swathes of the Mount Lebanon range and provided a source of wealth for the Phoenicians who exported the fragrant and durable wood to Egypt and Palestine.

The original Temple of Solomon in Jerusalem was built of this wood, as were many sarcophagi discovered in Egypt. A slow but sure process of deforestation took place over the millennia, and although new trees are now being planted. it will be centuries before they mature.

Of the few remaining ancient trees, most are in the grove at the Cedars, above Bcharre, and in Barouk, south of Beirut. Some of the trees at the Cedars are thought to be well over 1000 years old. Their trunks have a huge girth and their height can reach 30m. Naturally, there are strict rules about taking any timber from these remaining trees and the souvenirs for sale nearby are made from fallen branches.

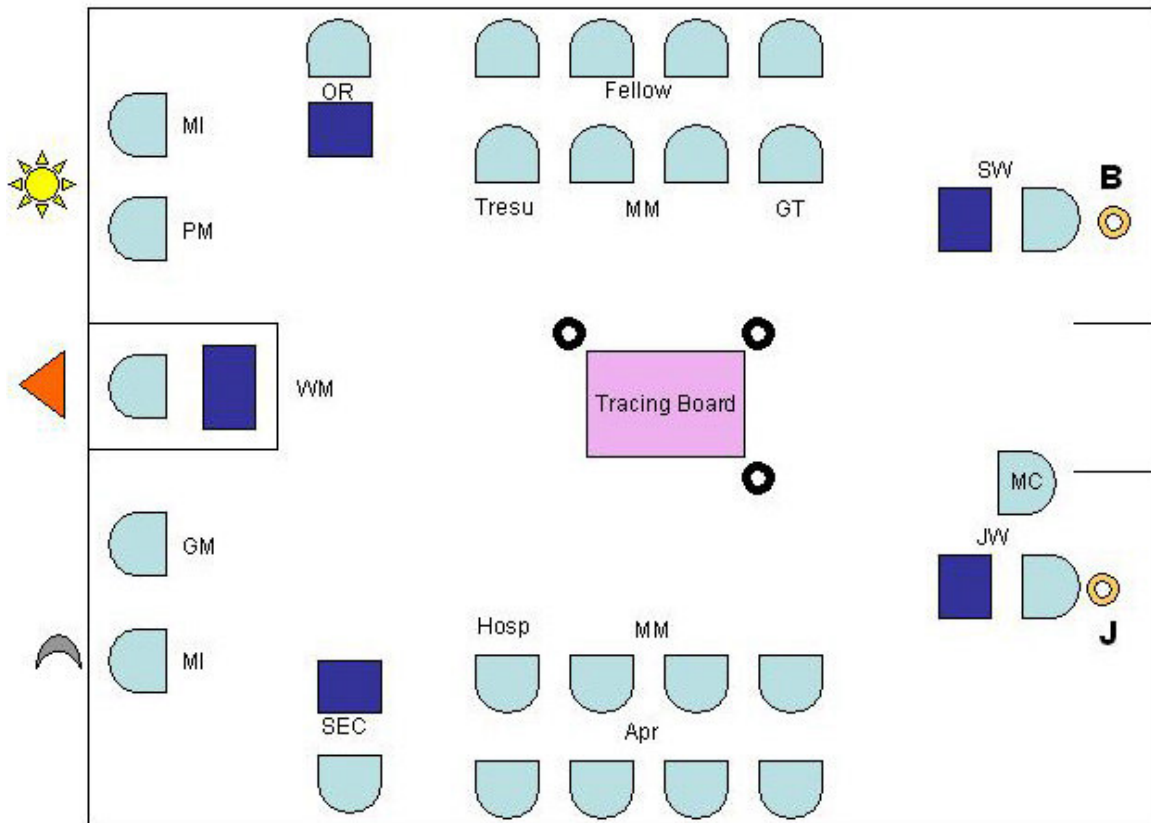

The Cooke Manuscript circa 1450

(Containing the Legend of the Craft)

THANKED be God, our glorious Father, the founder and creator of heaven and earth, and of all things that therein are, for that he has vouchsafed, of his glorious Godhead, to make so many things of manifold virtue for the use of mankind.

For he made all things to be subject and obedient to man. All things eatable of a wholesome nature he ordained for man's sustenance. And moreover, he hath given to man wit and the knowledge of divers things and handicrafts, by the which we may labour in this world, in order to therewith get our livelihood and fashion many objects, pleasant in the sight of God, to our own ease and profit. To rehearse all these matters here were too long in the writing or telling, I will therefore refrain; but I will nevertheless, tell you some ; for instance, how and in what manner the Science of Geometry was first invented, and who were the founders both thereof and of several other crafts, as is declared in the Bible, and other histories.

How, and in what manner this worthy Science of Geometry took its rise, I will tell you, as I said before. You must know that there are seven liberal sciences, from which seven all other sciences and crafts in the world sprung; but especially is Geometry the first cause of all the other sciences, whatsoever they be.

These seven sciences are as follows:

The first, which is called the foundation of all science, is grammar, which teacheth to write and speak correctly.

The second is rhetoric, which teaches us to speak elegantly.

The third is dialectic, which teaches us to discern the true from the false, and it is usually called art or sophistry (logic).

The fourth is arithmetic, which instructs us in the science of numbers, to reckon, and to make accounts.

The fifth is Geometry, which teaches us all about mensuration, measures and weights, of all kinds of handicrafts.

The sixth is music, and that teaches the art of singing by notation for the voice, on the organ, trumpet, and harp, and of all things pertaining thereto.

The seventh is astronomy, which teaches us the course of the sun and of the moon and of the other stars and planets of heaven.

Our intent is to treat chiefly of the first foundation of Geometry and who were the founders thereof. As I said before, there are seven liberal sciences, that is to say, seven sciences or crafts that are free in themselves, the which seven exist only through Geometry. And Geometry may be described as earth-mensuration, for Geometry is derived from geo, which is in Greek "earth," and metrona or a measure. Thus is the word Geometry compounded and signifies the measure of the earth.

Marvel not because I said that all sciences exist only through the science of Geometry. For there is no art or handicraft wrought by man's hands that is not wrought by Geometry which is a chief factor (notabulle cause) thereof. For if a man work with his hands he employs some sort of tool, and there is no instrument of any material in this world which is not formed of some sort of earth (ore) and to earth it will return. And there is no instrument or tool to work with that has not some proportion, more or less. And proportion is measure, and the instrument or tool is earth. And Geometry is earthmensuration therefore I affirm that all men live by Geometry. For all men here to this world live by the labour of their hands.

Many more proofs could I give you that Geometry is the science by which all reasoning men live, but I refrain at this time because the writing of it were a long process.

And now I will enter further into the matter You must know that among all the crafts followed by man in this world, Masonry has the greatest renown and the largest share of this science of Geometry, as is stated in history, such as the Bible, and the Master of History," and in the Policronicon a well authenticated (or trustworthy) chronicle, and in the history called Beda De Imagine Mundi, and Isidorus Ethomolegiarum Methodius Episcopus & Martiris. And many others say that Masonry is the chief part of Geometry and so methinks it may well be said, for it was the first founded, as is stated in the Bible, in the first book of Genesis and the fourth chapter. And moreover all the learned authors above cited agree thereto. And some of them affirm it more openly and plainly, precisely as in Genesis in the Bible.

Before Noah's Flood by direct male descent from Adam in the seventh generation, there lived a man called Lamech who had two wives, called Adah and Zillah. By the first wife, Adah, he begat two sons, Jabal and Jubal. The elder son Jabal was the first man that ever discovered geometry and masonry, and he made houses, and is called in the Bible the father of all men who dwell in tents or dwelling houses. And he was Cain's master mason and governor of the works when he built the city of Enoch, which was the first city ever made and was built by Cain, Adam's son, who gave it to his own son Enoch, and give the city the name of his son and called it Enoch, and now it is known as Ephraim. And at that place was the Science of Geometry and Masonry first prosecuted and contrived as a science and as a handi-craft. And so we may well say that it is the first cause and foundation of all crafts and sciences. And also this man Jabel was called the father of shepherds. The Master of History says, and Beda De Imagine Mundi and the Policronicon and many others more say, that he was the first that made partition of lands, in order that every man might know his own land and labour thereon for himself. And also he divided flocks of sheep, that every man might know his own sheep, and so we may say that he was the inventor of that science.

And his brother Jubal or Tubal was the inventor of music and song, as Pythagoras states in Polycronicon, and the same says Isidorous. In his Ethemolegiis in the 6th book he says that he was the first founder of music and song, and of the organ and trumpet; and he discovered that science by the sound of the weights of his brother's, Tubal-Cain's, hammers.

And of a truth, as the Bible says, that is to say, in the fourth Chapter of Genesis, Lamech begat by his other wife Zillah a son and a daughter, and their names Tubal Cain, that was the son, and the daughter was called Naamah. And according to the Policronicon, some men say that she was Noah's wife; but whether this be so or not, we will not affirm.

Ye must know that this son Tubal Cain was the founder of the smith's craft and of other handicrafts dealing with metals, such as iron, brass, gold and silver as some learned writers say; and his sister Naamah discovered the craft of weaving for before her time no cloth was woven, but they span yarn and knit it and made such clothing as they could. And as this woman Naamah invented the craft of weaving it was called woman's-craft.

And these four brethren knew that God would take vengeance for sin, either by fire or water. And they were much concerned how to save the sciences they had discovered, and they took counsel together and exercised all their wits. And they said there were two kinds of stone of such virtue that the one would not burn, called marble, and the other named "Lacerus" would not sink in water. And so they devised to write all the sciences they had found on these two stones, so that if God took vengeance by fire the marble would not burn, and if by water the other would not drown, and they besought their elder brother Jabal to make two pillars of these two stones, that is of marble and of "Lacerus," and to write on the two pillars all the sciences and crafts which they had found and he did so. And therefore we may say that he was the wisest in science, for he first began and carried out their purpose before Noah's flood, Fortunately knowing of the vengeance that God would send, the brethren knew not whether it would be by fire or water. They knew by a sort of prophecy that God would send one or the other, and therefore they wrote their sciences on the two pillars of stone. And some men say that they wrote on the stones all the seven sciences, but [this I affirm not]. As they had it in mind that a vengeance would come, so it befell that God did send vengeance, and there came such a flood that all the world was drowned and all men died save only eight persons. These were Noah and his wife and his three sons and their wives, of which sons all the world is descended, and they were named in this wise, Shem, Ham and Japhet. And this flood is called Noah's Flood, for he and his children were saved therein. And many years after the flood, according to the chronicle, these two pillars were found, and the chronicle says that a great clerk, Pythagoras, found the one, and Hermes the philosopher found the other, and they taught the sciences that they found written thereon.

Every chronicle and history and many other writers and the Bible especially relate the building or the tower of Babel; and it is written in the Bible, Genesis, Chap. x how that Ham, Noah's son, begat Nimrod, who grew a mighty man upon the earth and waxed strong, like unto a giant. He was a great king and the beginning of his kingdom was the kingdom of Babilon proper, and Erech and Arend and Calneh and the land of Shinar. And this same Ham began the tower of Babel and taught his workmen the Craft of Masonry and he had with him many masons, more than 40,000, and he loved and cherished them well. And it is written in Polycronicon, and in the Master of History, and in other histories, and beyond this the Bible witnesses in the same 10th chapter, as it is written, that Ashur who was of near kindred to Nimrod went forth from the land of Shinar and built the City of Nineveh and Plateas (sic) and many more. For it is written "Do terra illa" [&c.]

It is but reasonable that we should plainly say how and in what manner the Charges of the Mason's Craft were first founded, and who first gave it the name of Masonry And you most know that it is stated and written in the Polycronicon and in Methothus Episcopus and Martiris that Ashur who was a worthy lord of Shinar, sent to Nimrod the king to send him Masons and workmen of the Craft that they might help him make his city which he was minded to make. And Nimrod sent him 3000 masons. And as they were about to depart and go forth, he called them before him and said to them, "Ye must go to my cousin Ashur to help him build a city, but see to it, that ye be well governed, and I will give you a Charge that shall be to your and my profit.

"When you come to that lord, look that you be true to him, even as you would be to me, labour at your Craft honestly, and take a reasonable payment for it such as you may deserve. Love each other as though you were brothers and hold together staunchly. Let him that hath most skill teach his fellow, and be careful that your conduct amongst yourselves and towards your lord may be to my credit, that I may have thanks for sending you and teaching you the Craft." And they received the charge from him, being their lord and master, and went forth to Ashur and built the city of Nineveh in the country of Plateas (sic) and other cities also that are called Calah and Rosen, which is a great city between Calah and Nineveh. And in this manner the Craft of Masonry was first instituted and charged as a science.

Elders of Masons before our times had these charges in writing as we have them now in our Charges of the story of Euclid, and as we have seen them written both in Latin and in French.

But it is only reasonable that we should tell you how Euclid came to the knowledge of Geometry, as stated in the Bible and in other histories. In the XIIth chapter of Genesis it is told how Abraham came to the land of Canaan and our Lord appeared unto him and said, "I will give this land to thy seed." But a great famine reigned in that land and Abraham took Sarah, his wife, with him and made a journey into Egypt to abide there whilst the famine lasted. And Abraham, so says the chronicle, was as a wise man and a learned. And he knew all the seven sciences and taught the Egyptians the science of Geometry. And this worthy clerk Euclid was his pupil and learned of him. And he first gave it the name of Geometry; although it was practised before his time, it had not acquired the name of Geometry. But it is said by Isodoras in the 5th Book and first Chapter of Ethomolegiarum that Euclid was one of the first founders of Geometry and gave it that name.

For in his time, the river of Egypt which is called the Nile so overflowed the land that no man could dwell therein. Then the worthy clerk Euclid taught them to make great walls and ditches to keep back the water, and by Geometry he measured the land and parcelled it out into sections and caused every man to enclose his own portion with walls and ditches and thus it became a country abounding in all kinds of produce, and of young people and of men and women: so that the youthful population increased so much as to render earning a livelihood difficult. And the lords of the country drew together and took counsel how they might help their children who had no competent livelihood in order to provide for themselves and their children, for they had so many. And at the council amongst them was this worthy Clerk Euclid and when he saw that all of them could devise no remedy in the matter he said to them "Lay your orders upon your sons and I will teach them a science by which they may live as gentlemen, under the condition that they shall be sworn to me to uphold the regulations that I shall lay upon them." And both they and the king of the country and all the lords agreed thereto with one consent.

It is but reasonable that every man should agree to that which tended to profit himself; and so they took their sons to Euclid to be ruled by him and he taught them the Craft of Masonry and gave it the name of Geometry on account of the parcelling out of the ground which he had taught the people at the time of making the walls and ditches, as aforesaid, to keep out the water. And Isodoris says in Ethomologies that Euclid called the craft Geometry.

And there this worthy clerk Euclid gave it a name and taught it to the lord's sons of that land whom he had as pupils. And he gave them a charge. That they should call each other Fellow and no otherwise, they being all of one craft and of the same gentle birth, lords' sons. And also that the most skilful should be governor of the work and should be called master; and other charges besides, which are written in the Book of Charges. And so they worked for the lords of the land and built cities and towns, castles and temples and lords' palaces.

During the time that the children of Israel dwelt in Egypt they learned the craft of Masonry. And after they were driven out of Egypt they came into the promised land, which is now called Jerusalem, and they occupied that land and the charges were observed there. And [at] the making of Solomon's Temple which king David began, King David loved masons well, and gave them [wages] nearly as they are now. And at the making of the Temple in Solomon's time, as stated in the Bible in the third book of Kings and the fifth chapter, Solomon held four score thousand masons at work. And the son of the king of Tyre was his master mason. And in other chronicles and in old books of masonry, it is said that Solomon confirmed the charges that David his father had given to masons. And Solomon himself taught them their usages differing but slightly from the customs now in use.

And from thence this worthy science was brought into France and into many other regions. At one time there was a worthy king in France called Carolus Secundus, that is to say Charles the Second. And this Charles was elected king of France by the grace of God and also by right of descent. And some men say he was elected by good fortune, which is false as by the chronicles he was of the blood royal. And this same king Charles was a mason before he became king. And after he was king he loved masons and cherished them and gave them charges and usages of his devising, of which some are yet in force in France; and he ordained that they should have an assembly once a year and come and speak together in order that the masters and follows might regulate all things amiss.

And soon after that came St. Adhabelle into England and he converted St. Alban to Christianity. And St. Alban loved well masons and he was the first to give them charges and customs in England, And he ordained [wages] adequate to pay for their toil.

And after that there was a worthy king in England, called Athelstan, and his youngest son loved well the science of Geometry; and he know well, as well as the masons themselves, that their handicraft was the practice of the science of Geometry. Therefore he drew to their councils (or took counsel, or lessons, of them) and learned the practical part of that science in addition to his theoretical (or book) knowledge. For of the speculative part he was a master. And he loved well masonry and masons. And he became a mason himself. And he give them charges and usages such as are now customary in England and in other countries. And he ordained that they should have reasonable pay. And he purchased a free patent of the king that they might hold an assembly at what time they thought reasonable and come together to consult. Of the which charges, usages and assembly it is written and taught in our Book of Charges; wherefore I leave it for the present.

Good men! for this cause and in this way Masonry first arose. It befell, once upon a time, that great lords had so many free begotten children that their possessions were not extensive enough to provide for their future. Therefore they took counsel how to provide for their children and find them all honest livelihood. And they sent for wise masters of the worthy science of Geometry, that through their wisdom they might provide them with some honest living. Then one of them that was called Euclid a most subtil and wise inventor regulated [that science] and art and called it Masonry. And so in this art of his he honestly taught the children of great lords according to the desire of the fathers and the free consent of their children. And having taught them with great care for a certain time they were not all alike capable of exercising the said art, wherefore the said master Euclid ordained that those that surpassed the others in skill should be honoured above the others. And [comman]ded to call the more skilful "master" and for [him] to instruct the less skilful. The which masters were called masters of nobility, of knowledge and skill in that art. Nevertheless they commanded that they that were of less knowledge should not be called servants or subjects, but fellows, on account of the nobility of their gentle blood. In this manner was the aforesaid art begun in the land of Egypt by the aforesaid master Euclid and so it spread from country to country and from kingdom to kingdom Many years after, in the time of king Athelstan, sometime king of England, by common assent of his Council and other great lords of the land on account of great defects found amongst masons, a certain rule was ordained for them.

Once a year or every three years as might appear needful to the king and great lords of the land and all the community, congregations should be called by the masters from country to country and from

province to province of all masters, masons and fellows in the said art. And at such congregations those that are made masters shall be examined in the articles hereafter written and be ransacked whether they be able and skilful in order to serve the lords to their profit and to the honour of the aforesaid art. And moreover they shall be charged to well and truly expend the goods of their lords, as well of the lowest as of the highest; for those are their lords for the time being of whom they take their pay in recompense of their service and toil.

The first article is this. That every master of this art should be wise, and true to the lord who employs him, expending his goods carefully as he would his own were expended; and not give more pay to any mason than he knows him to have earned, according to the dearth (or scarcity and therefore price) of corn and victuals in the country and this without favouritism, for every man is to be rewarded according to his work.

The Second article is this. That every master of the art shall be warned beforehand to come to his congregation in order that he may duly come, there, unless he may [be] excused for some cause or other. But if he be found [i.e., accused of being] rebellious at such congregation, or at fault in any way to his employer's harm or the reproach of this art, he shall not be excused unless he be in peril of death. And though he be in peril of death, yet must, he give notice of his illness, to the master who is the president of the gathering.

The [third] article is this. That no master take no apprentice for a shorter term than seven years at least, for the reason that such as have been bound a shorter time can not adequately learn their art, nor be able to truly serve their employer and earn the pay that a mason should.

The fourth article is this. That no master shall for any reward take as an apprentice a bondsman born, because his lord to whom he is a bondsman might take him, as he is entitled to, from his art and carry him away with him from out the Lodge, or out of the place he is in. And because his fellows peradventure might help him and take his part, and thence manslaughter might arise; therefore it is forbidden. And there is another reason; because his art was begun by the freely begotten children of great lords, as aforesaid.

The fifth article is this. That no master shall pay more to his apprentice during the time of his apprenticeship, whatever profit he may take thereby, than he well knows him to have deserved of the lord that employs him ; and not even quite so much, in order that the lord of the works where he is taught may have some profit by his being taught there.

The sixth article is this. That no master from covetousness or for gain shall accept an apprentice that is unprofitable; that is, having any maim (or defect) by reason of which he is incapable of doing a mason's proper work.

The seventh article is this. That no master shall knowingly help or cause to be maintained and sustained any common nightwalker robber by which nightwalking they may be rendered incapable of doing a fair day's work and toil: a condition of things by which their fellows might be made wrath. The eighth article is this. Should it befall that a perfect and skilful mason come and apply for work and find one working who is incompetent and unskilful, the master of the place shall discharge the incompetent and engage the skilful one, to the advantage of the employer.

The ninth article is this. That no master shall supplant another. For it is said in the art of masonry that no man can so well complete a work to the advantage of the lord, begun by another as he who began it intending to end it in accordance with his own plans, or [he] to whom he shows his plans. These regulation following were made by the lords (employers) and masters of divers provinces and divers congregations of masonry.

[First point] To wit: whosoever desires to become a mason, it behoves him before all things to [love] God and the holy Church and all the Saints; and his master and follows as his own brothers.

The second point. He must give a fair day's work for his pay.

The third [point]. He shall hele the counsel or his fellows in lodge and in chamber, and wherever masons meet.

The fourth point. He shall be no traitor to the art and do it no harm nor conform to any enactments against the art nor against the members thereof: but he shall maintain it in all honour to the best of his ability.

The fifth point. When he receives his pay he shall take it without murmuring, as may be arranged at the time by the master; and he shall fulfil the agreement regarding the hours of work and rest, as ordained and set by the master.

The sixth point. In case of disagreement between him and his fellows, he shall unquestioningly obey the master and be silent thereon at the bidding of his master, or of his master's warden in his master's absence, until the next following holiday and shall then settle the matter according to the verdict of his fellows; and not upon a work-day because of the hindrance to the work and to the lord's interests.

The seventh point. He shall not covet the wife nor the daughter of his master or of his fellows unless it be in marriage neither shall he hold concubines, on account of the discord this might create amongst them.

The eighth point. Should it befall him to be his master's warden, he shall be a true mediator between his master and his fellows: and he shall be active in his master's absence to the honour of his master and the profit of the lord who employs him.

The ninth point. If he be more wise and skilful than his fellow working with him in the Lodge or in any other place, and he perceive that for want of skill, he is about to spoil the stone upon which he is working and can teach him to improve the stone, he shall instruct and help him ; so that love may increase the more amongst them and the work of his employer be not lost.

When the master and fellows, being forewarned are come to such congregations, the sheriff of the country or the mayor of the city or alderman of the town in which the congregation is held, shall if need be, be fellow and associate of the master of the congregation, to help him against disobedient members to maintain the rights of the realm.

And at the commencement of the proceedings, new men who have never been charged before are to be charged in this manner. Ye shall never be thieves nor thieves' maintainers, and shall do a fair day's work and toil for your pay that you take of the lord, and shall render true accounts to your fellows in all matters which should be accounted for to them, and love them as yourselves. And ye shall be true to the king of England and to the realm: and that ye keep with all your might and [power] all the aforesaid articles.

After that an enquiry shall be held whether any master or fellow summoned to the meeting, have broken any of the beforesaid articles, which, if they have done, it shall be then and there adjudicated upon.

Therefore be it known; if any master or fellow being forewarned to come to the congregation, be contumacious and appear not; or having trespassed against any of the aforesaid articles shall be convicted; he shall forswear his masonry and shall no longer exercise the craft. And if he presume so to do, the sheriff of the country in which he may be found at work shall put him in prison and take all his goods for the use of the king, until his (the king's) grace be granted and showed him. For this cause chiefly were these congregations ordained; that the lowest as well as the highest might be well and truly served in the aforesaid art throughout all the kingdom of England.

Amen, so mote it be.

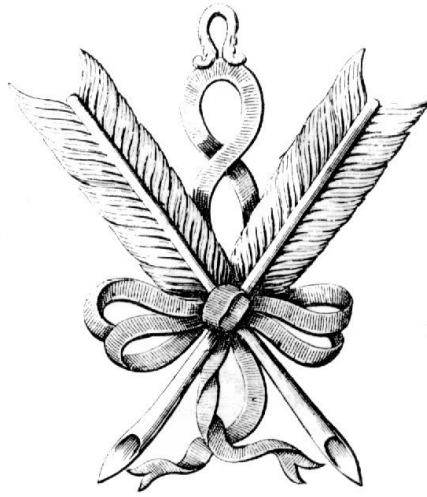

Rules for visiting

There are four rules relating to visiting in recognised or unrecognised jurisdictions.

- 1 - A Mason may only visit constituent lodges under a Grand Lodge recognised by the Masonic High Council the Mother High Council.
- 2 - If a Mason owes allegiance to two Grand Lodges, he may then only visit lodges in a third jurisdiction recognised by both, unless all the Grand Lodges involved permit otherwise.
- 3 - If a Mason lawfully visits a lodge in another jurisdiction and finds another visitor lawfully present, whose Grand Lodge is not in amity with the Masonic High Council the Mother High Council of the World, then the Mason must withdraw, unless the MHC and the host's Grand Lodge both permit otherwise.
- 4 - A lodge may only admit visitors from jurisdictions formally recognised by the Masonic High Council the Mother High Council of the World, unless the MHC has instructed its lodges otherwise.

If this is not practicable, the strictest version of the above rules should be abided by. The safest course is for Brethren to obtain advice from the Masonic High Council the Mother High Council of the World prior to visiting. It is important to keep this advice in mind when reading these rules because the MHC will be able to provide up to date information about lodges and Grand Lodges, which may not be recognised.

Important News

Dear Brethren,

Our Grand Secretary's staffs are working hard to ensure that this newsletter is prepared and sent out to all of you on a regular basis. We urge you all to send in all items, which you may, feel are of interest to the thousands of brethren who receive this newsletter. Although we cannot always guarantee publication we can certainly promise not to if you do not send it! Although we will not publish your name if you do not wish us to, please give your details.

We look forward to receiving many of your items.

From the staff of the Office of the Grand Secretary, Regular Grand Lodge of England

All enquiries, submissions and articles should be sent to the attention of the:

**Secretary General
Masonic High Council**

e-mail: masoniccouncil@gmail.com

"We are unable to return material submitted by individual brethren. Any submissions which are not signed will not be considered for publication."